



B



A

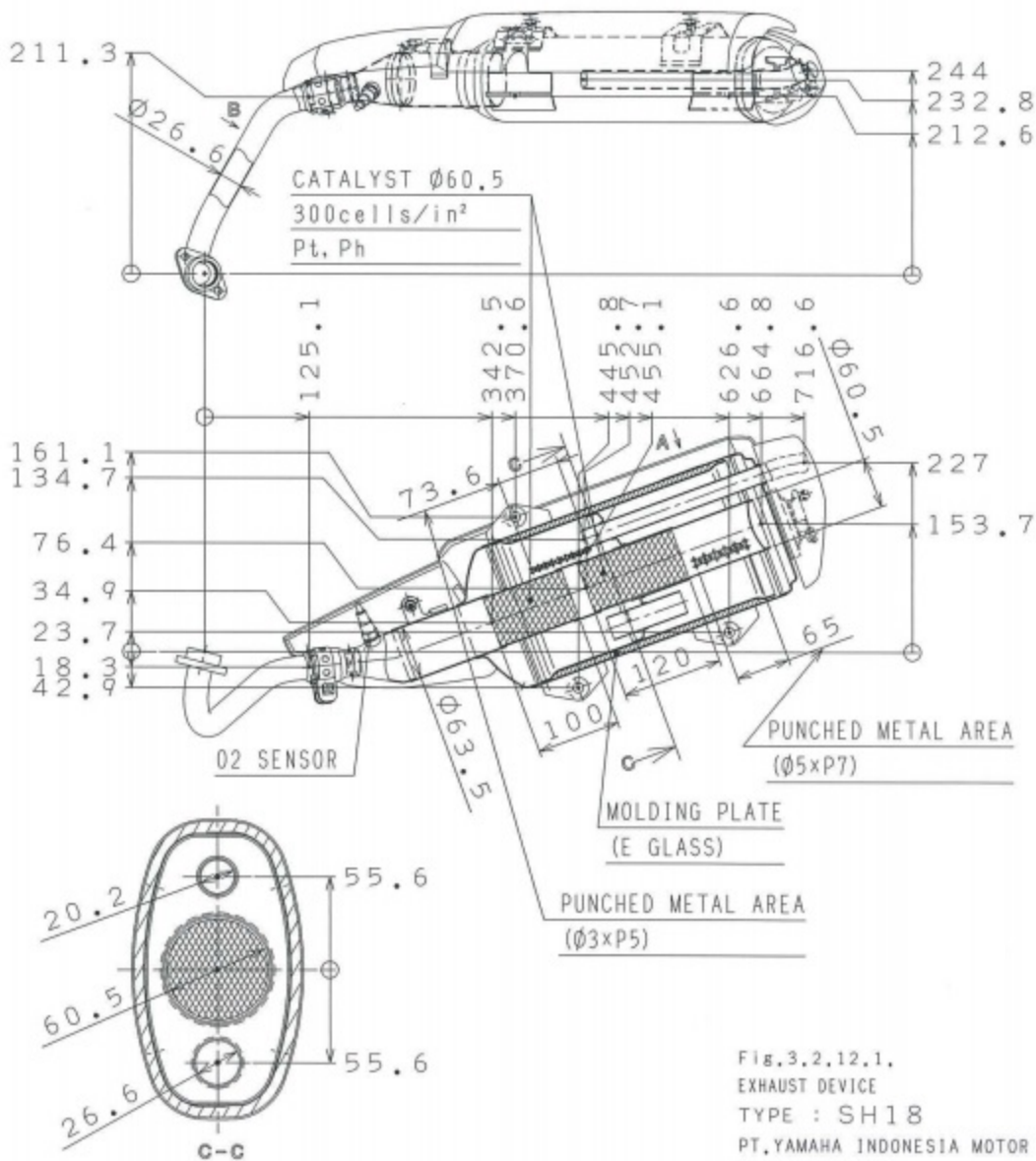
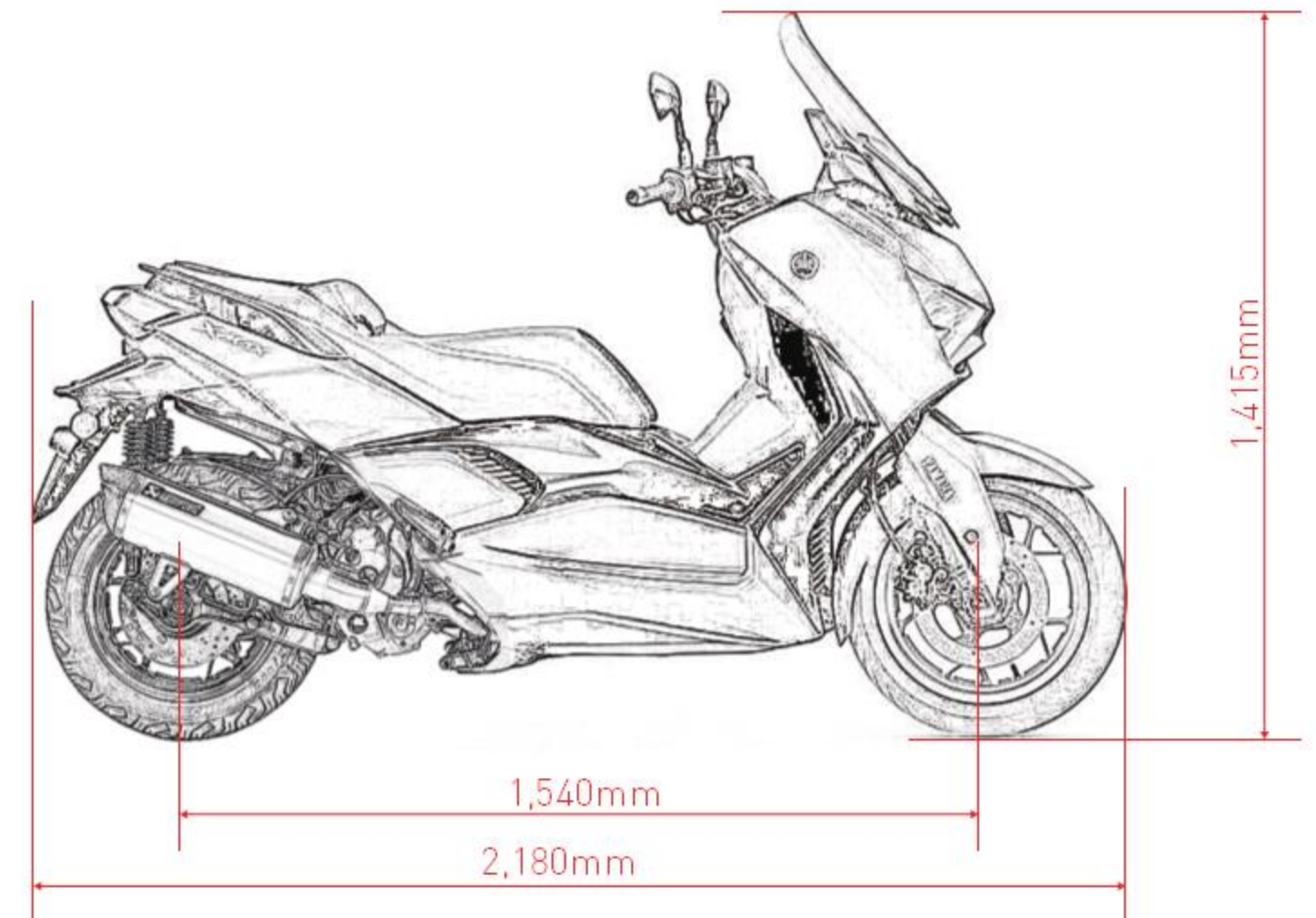
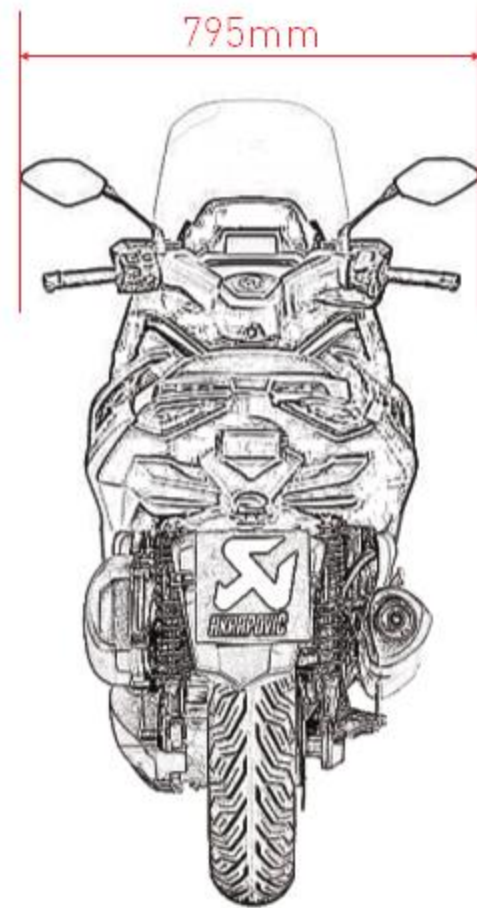
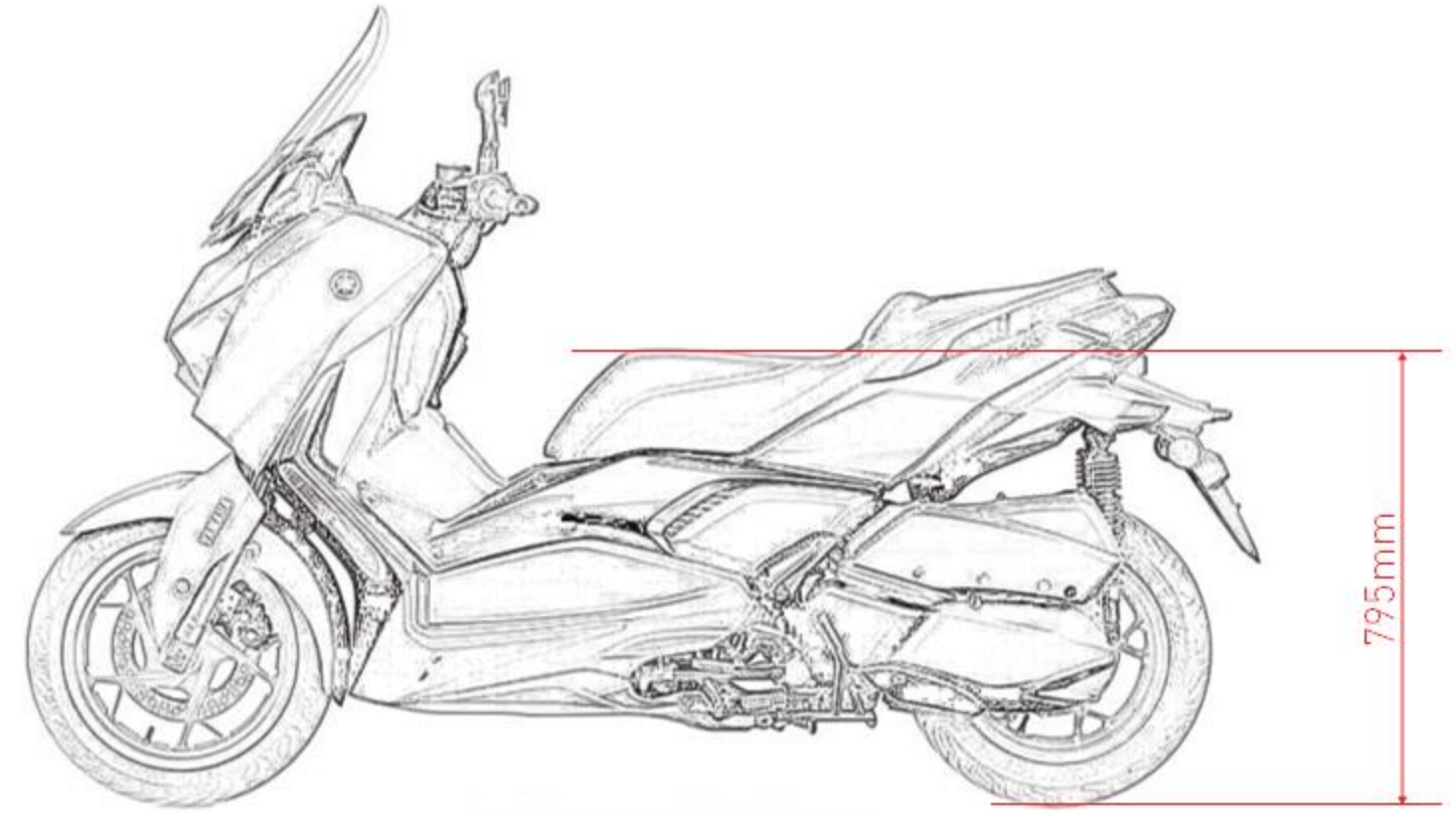
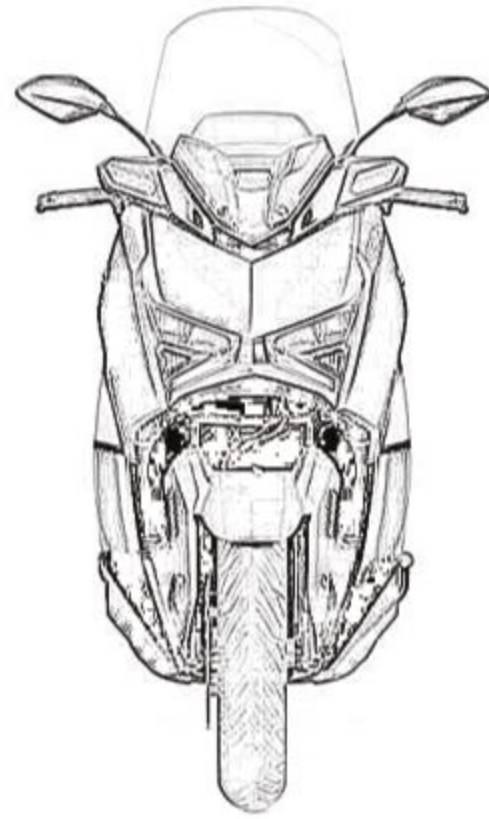
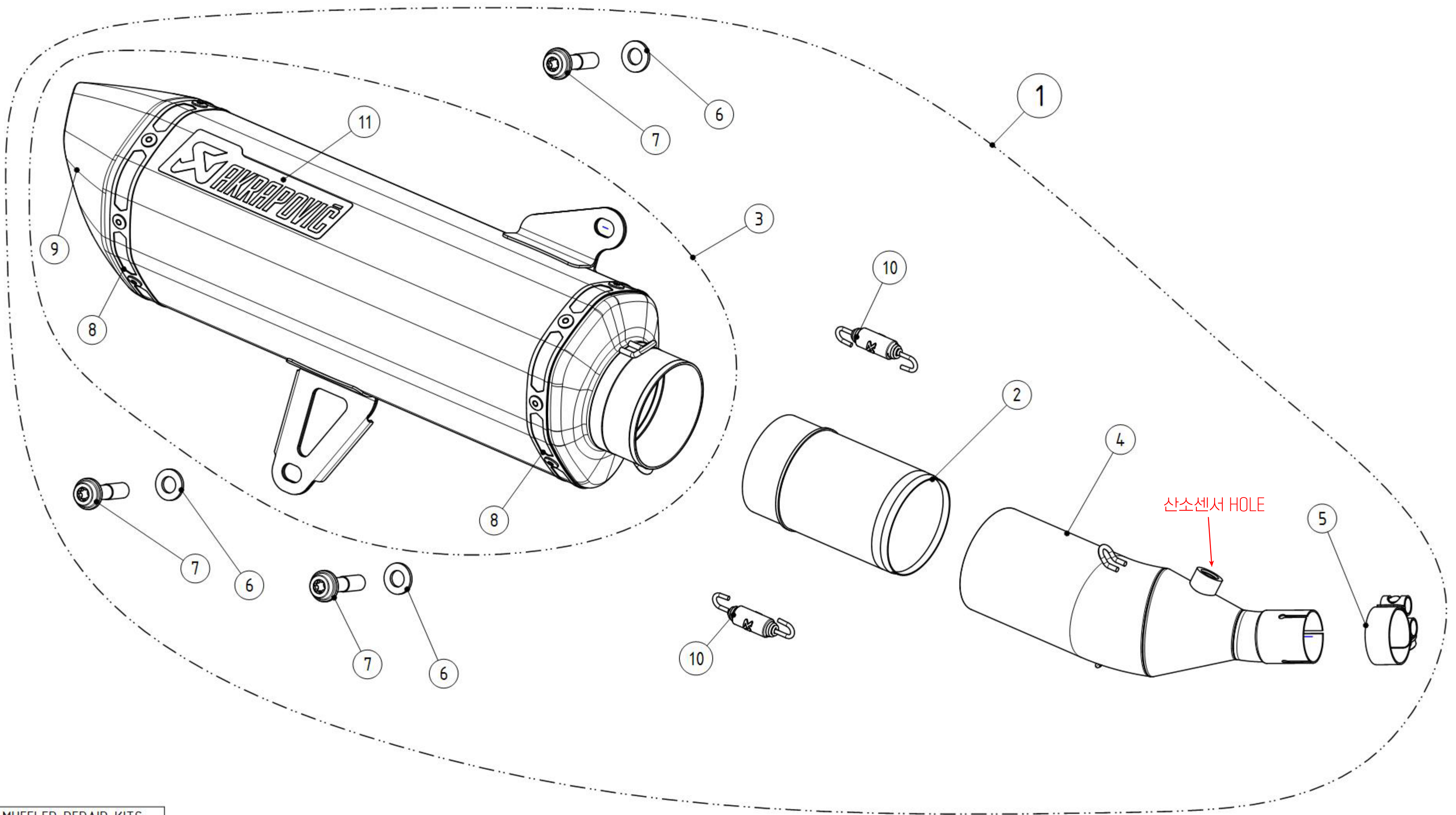

FIG.3.2.12.1.
 EXHAUST DEVICE
 TYPE : SH18
 PT.YAMAHA INDONESIA MOTOR
 MANUFACTURING





MUFFLER REPAIR KITS	
REPACK	12
SLEEVE	13

No.	SalesCode	Description	Qty.
1	S-Y3SO3-HRSS	slip on system	1
2	P-KAT-089	catalytic converter	1
3	M-HR07502SS	muffler	1
4	L-Y3SO3	link pipe SS	1
5	P-R52	clamp SS	1
6	P-DR41	washer SS	3
7	P-FB173	bolt	3
8	P-TT45	belt TI for SS sleeve	2
9	V-EC280	end cap CA	1
10	P-S2/1	spring	2
11	P-HST6AL	sticker	1
12	P-RPCK246	repack kit	1
13	P-RKS702R350	muffler sleeve kit	1
14	V-TUV268	insert SS	1

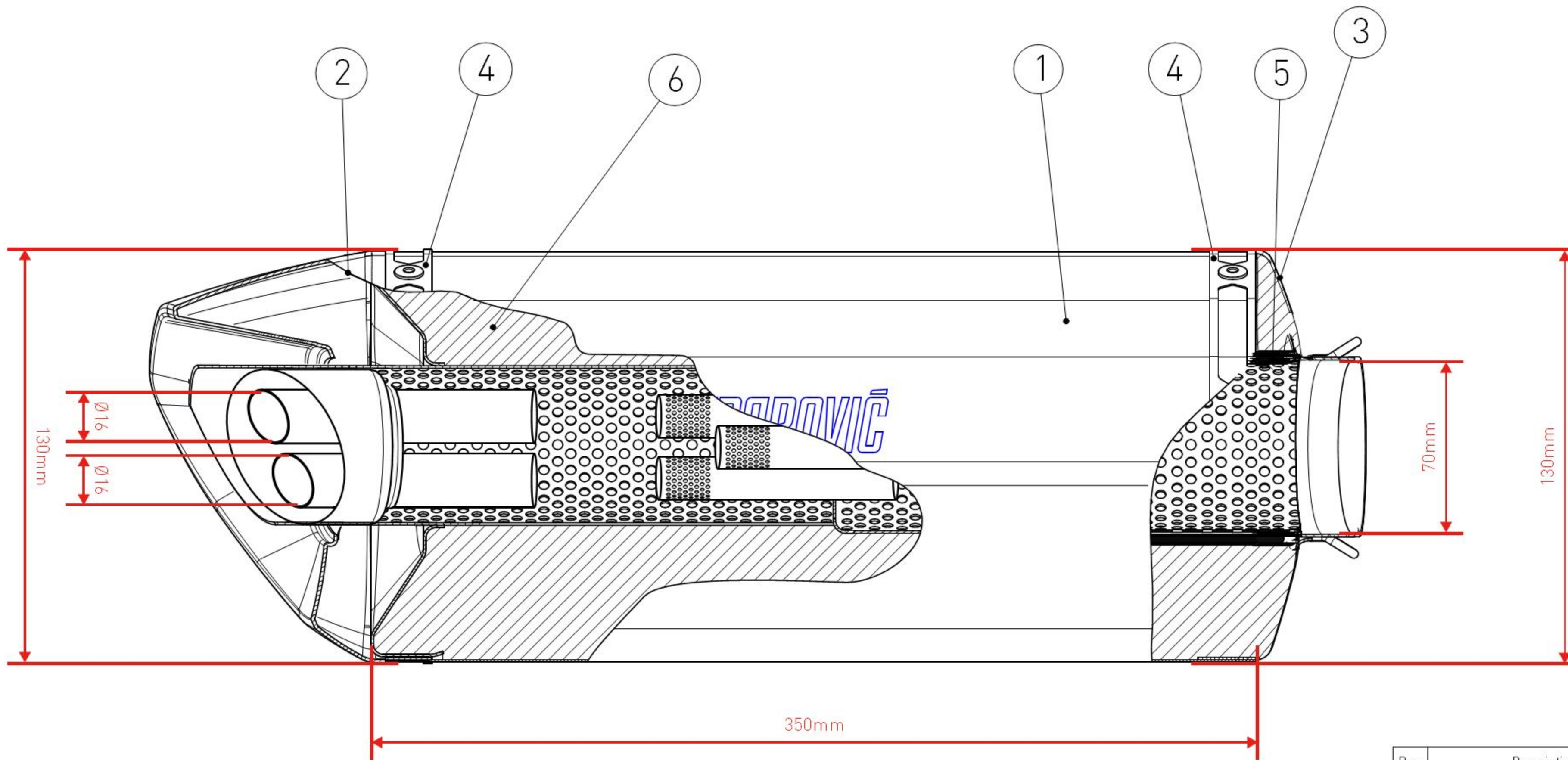

Pos.	Description
1	Outer sleeve
2	End cap set
3	Rosette assembly
4	Belt
5	Perforated tube
6	Damping material



OPIS
Muffler cross section slip-ON