

**KAWASAKI ZX-6R (2019- PRESENT) DIY WINDSCREEN INSTALL**

**Installation Instructions for 20, 16, 23, 24, 25 Series  
Windscreen 2019 - Present Kawasaki ZX-6R**

**PLEASE READ BEFORE  
MOUNTING YOUR WINDSCREEN**

Thank you for purchasing a Zero Gravity windscreen. This instruction manual gives you an in-depth look at the installation process. To receive further assistance or parts please e-mail [techinfo@zerogravity-racing.com](mailto:techinfo@zerogravity-racing.com).

**Helpful hints: Use metric tools, clean hands, put the bike on a center stand. Do not pry on the screen excessively, as it can break without much warning.**

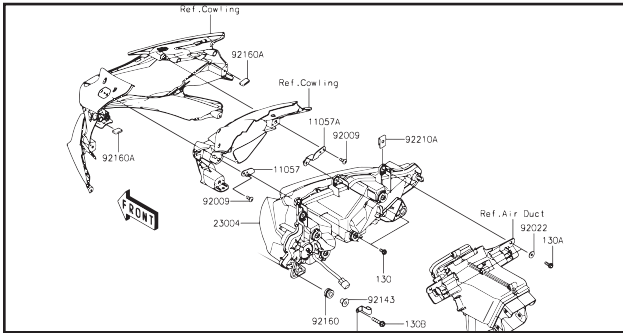

**Part 1 Removing Factory Screen Over View / Remove side mirrors**

Overview of screen & exploded view of assembly. Before starting disassembly, please review this instruction sheet to better understand the install/uninstalled process.



**Part 4 Pulling the upper fairing inserting ZG screen**

Start by inserting the windscreen from one side first. To slide in the windscreen, grab and gently pull up on the upper fairing to provide room for the upper wellnut.

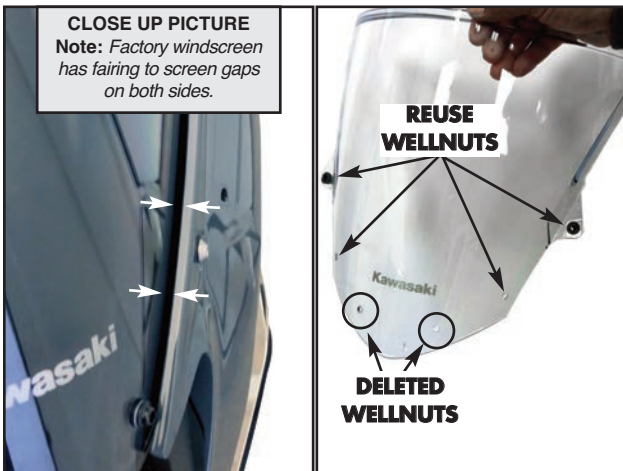

**CLOSE UP PICTURE**

**Note:** Factory windscreen has fairing to screen gaps on both sides.

**Part 2 How to remove factory screen**

Remove factory screen by unscrewing the Allen screws on the windscreen and sliding it upwards from the fairing.

**Note:** Both TOP & MIDDLE silver allen screws are used on your new Zero Gravity screen, the BOTTOM two black Allen screws are deleted.



**Part 5 Wellnut alignment & inserting allen screws to finish install**

Once the screen is in position, the factory middle wellnuts may need to be aligned with the ZG windscreen fastener holes. Use an allen key, as shown above, to make the alignment. Insert the four allen screws to finish the installation.

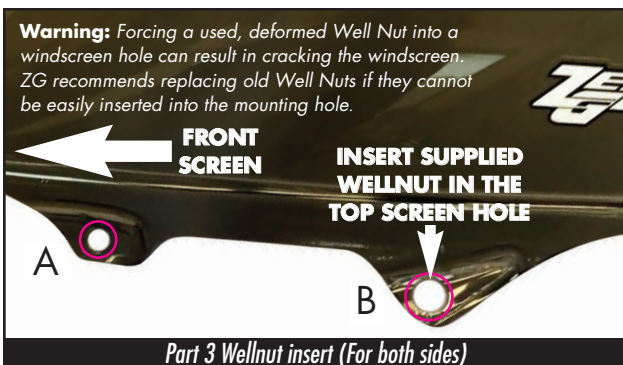

**Part 3 Wellnut insert (For both sides)**

Insert wellnut (2) supplied in your new ZG screen into hole B on both sides. **Note:** Not recommended reusing factory deformed wellnuts.



Zero Gravity Windscreen installed.