

Copyright© 2001 by Big Bike Parts, Inc. No part of this instruction sheet may be reproduced without the written permission of Big Bike Parts, Inc.©

Updated 2/12/2009

ITEMS REQUIRED: PHILLIPS SCREWDRIVER 8MM WRENCH  
DRILL 5MM ALLEN WRENCH  
3/8" DRILL BIT 6MM ALLEN WRENCH

#### INSTALLATION:

1. APPLY SEAL TO SPEAKERS UNIT. USE SCISSORS, CUT THE SEAL INTO TWO EQUAL PORTIONS.
2. REMOVE THE PASSENGER HANDLES USING 6MM ALLEN WRENCH, REMOVE THE SEAT AND SIDE COVERS.
3. DISCONNECT THE NEGATIVE BATTERY CABLE.
4. REMOVE THE FOUR SCREWS (1A) ON EACH SIDE HOLDING THE RIGHT AND LEFT POCKETS ON.
5. REMOVE THE INNER TRUNK LID (2A) BY REMOVING THE PHILLIPS HEAD SCREWS (2B) THAT HOLD IT ON.
6. USING 8MM WRENCH REMOVE THE 3 BOLTS (3B) ON THE HINGE ASSEMBLY, BOTH SIDES.
7. REMOVE THE TWO PHILLIPS HEAD SCREWS (4A) HOLDING SPEAKER BOX (4C, 4D) ONTO TRUNK, BOTH SIDES.
8. USING A 5MM ALLEN WRENCH REMOVE THE TWO BOLTS (4B) HOLDING THE SPEAKER BOX (4C, 4D) TO TRUNK, BOTH SIDES.
9. REMOVE THE THREE PHILLIPS HEAD SCREWS (5A) HOLDING THE TWO PARTS OF THE SPEAKER BOX (5B, 5C) TOGETHER.
10. LOCATE THE "X" MARK (5D) ON THE BACK OF THE INNER SPEAKER BOX (5B) AND DRILL A 3/8" HOLE AT THAT POINT.
11. INSTALL THE SPEAKER (6B) INTO OUTER SPEAKER BOX (6C) USING THE SCREWS (6A) PROVIDED. BE SURE SPEAKER TERMINALS ARE AT THE TOP PORTION OF SPEAKER BOX.
12. REINSTALL THE INNER SPEAKER BOX TO THE HINGES BY REINSTALLING THE BOLTS REMOVED IN #6.
13. RUN THE SPEAKER WIRE HARNESS THROUGH THE DRILLED HOLES AND CONNECT THEM TO SPEAKERS. BE SURE TO USE THE LONG SIDE OF WIRE HARNESS ON RIGHT SIDE SPEAKER.
14. SECURE THE WIRE HARNESS USING THE SMALL WIRE TIES. BE SURE THAT THEY WILL NOT GET PINCHED IN THE TRUNK HINGE.
15. REINSTALL THE TRUNK LID BY REVERSING STEPS 7-8.
16. PLUG THE WIRE HARNESS INTO THE BLACK 4-PIN CONNECTOR (7A) ON BIKE.
17. SECURE THE WIRE HARNESS TO THE FRAME USING THE LONG WIRE TIES.
18. REINSTALL ALL PARTS REMOVED REVERSING STEPS 2-6.

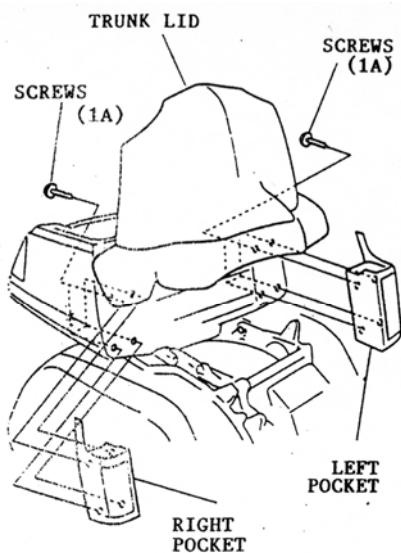

FIG 1

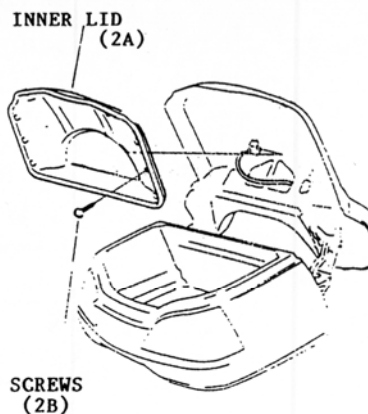

FIG 2

DIAGRAM ON BACK

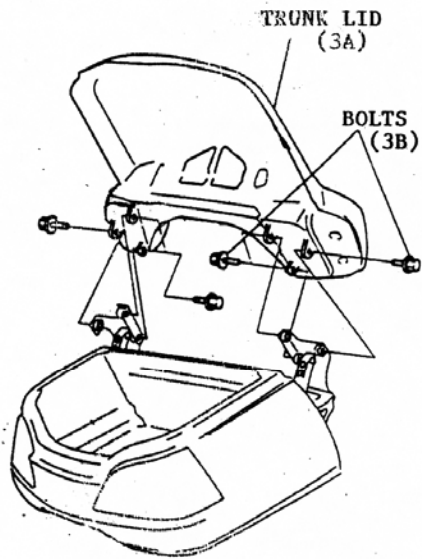

FIG 3

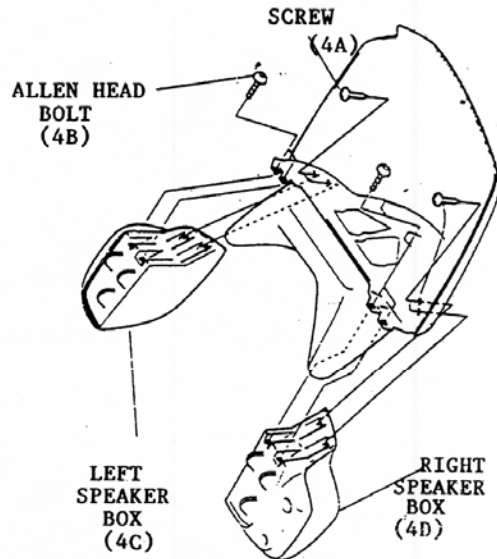

FIG 4

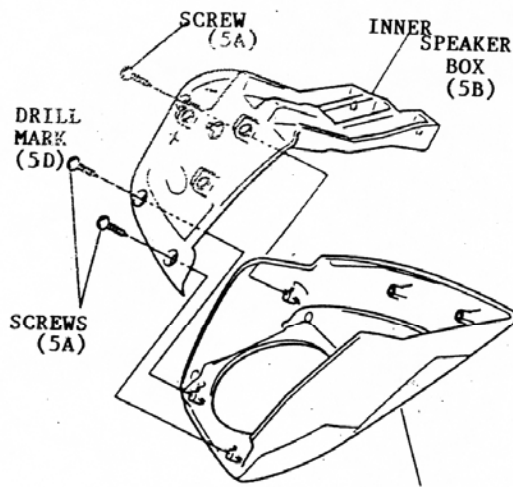

FIG 5

OUTER SPEAKER BOX (5C)

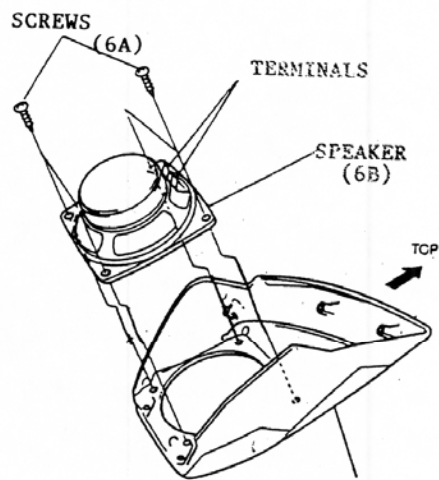

FIG 6

OUTER SPEAKER BOX (6C)

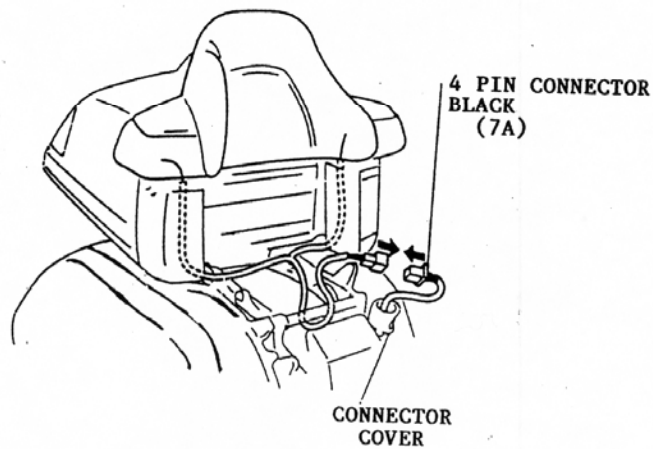

FIG 7