



**AKRAPOVIC SLIP-ON EXHAUST SYSTEM**  
**for the**  
**SUZUKI GSX-R1300 HAYABUSA**

**Congratulations on purchasing an Akrapovic exhaust system. Please read these installation instructions carefully. If you have any trouble installing the system please contact your authorized dealer!**

**IMPORTANT INFORMATION**

**Exclusion of Certain Liability**

1. The manufacturer, importer or dealer shall not be liable for any incidental damage including personal injury or any other damages caused by improper installation or operation of the Akrapovic exhaust system. When installing the Akrapovic exhaust system be careful that the exhaust system does not touch other parts sensitive to high temperature.
2. Akrapovic makes no representation or warranties with regard to damage caused by the improper installation, use and maintenance of the Akrapovic exhaust system. The warranty is limited to defects recognized by our technical department and to normal use, and excludes items subject to normal wear (gaskets and damping wool). The guarantee is void in case of accident, modification, improper or competition use.
3. Do not attempt to install the Akrapovic exhaust system on a motorcycle for which it was not made or tested by Akrapovic.
4. When the exhaust system gets very hot during operation, be careful not to burn yourself on the exhaust system or parts which are in direct contact with it, even when the motor is not running. Also protect other people, especially children, from the injuries mentioned above.
5. In some cases Akrapovic exhaust system kits contain chemical products (ceramic anti-seizing grease; bolt sealant). Handle with care, do not inhale or swallow. Avoid excessive contact with skin, eyes or mucous membranes. Keep out of reach of children.
6. Technical specifications of Akrapovic exhaust systems and related products subject to change without notice.

**Trademarks**

The Akrapovic Exhaust System Technology logo is a registered trademark of Akrapovic d.d.

**Akrapovic website**

Information about Akrapovic exhaust systems and related products is available on the Akrapovic website at:

**<http://www.akrapovic.com/>**

**Copyright**

No part of the Akrapovic exhaust system or its documentation may be reproduced or distributed in any form or by any means without the prior written authorization of the Akrapovic company.

© Akrapovic, d.d. All rights reserved.

**Symbols**

The following symbols are used throughout these installation instructions:



 **USE BOLT SEALANT;** Apply 3 to 4 small drops of bolt sealant onto the cleaned and degreased threads before tightening bolts. **WARNING! Avoid contact with skin, eyes and mucous membranes. Do not inhale fumes. Keep out of the reach of children.**

 **USE ANTI-SEIZING GREASE (white tube);** Prevents seizing, corrosion and excessive wear between the titanium components of your exhaust system. **WARNING! Avoid eye contact. Avoid excessive skin contact. Keep out of the reach of children.**

 **USE ANTI-SEIZE LEAD-FREE COPPER PASTE (black tube);** Provides trouble-free and long-lasting protection against seizing, corrosion and rusting of bolts, threaded ends, nuts, joints, etc. Also protects against vibration, wear and impact. **WARNING! Avoid eye contact. Avoid excessive skin contact. Keep out of the reach of children.**

## INSTALLATION INSTRUCTIONS

 BEFORE INSTALLING CHECK SCHEMATIC OF THE EXHAUST SYSTEM!

 IF ANY ITEMS IN THE AKRAPOVIC EXHAUST SYSTEM PACKAGE ARE MISSING PLEASE CONTACT YOUR AUTHORIZED DEALER. KEEP THE SCHEMATIC FOR FUTURE REFERENCE.

 THESE INSTALLATION INSTRUCTIONS MUST BE READ CAREFULLY IN ORDER TO ENSURE PROPER INSTALLATION AND OPERATION OF THE AKRAPOVIC EXHAUST SYSTEM.

 THE EXHAUST SYSTEM CAN BE EXTREMELY HOT. ALLOW THE MOTORCYCLE TO COOL DOWN BEFORE BEGINNING INSTALLATION.

 WE ADVISE YOU TO LEAVE INSTALLATION TO A QUALIFIED SERVICEMAN. IMPROPER INSTALLATION MAY RESULT IN A SHORTER LIFETIME OF THE EXHAUST SYSTEM AND/OR DAMAGE TO THE MOTORCYCLE.



T-handle 12mm wrench  
T-handle 4mm three hexagon key wrench  
T-handle 5mm three hexagon key wrench  
Combination 12mm wrench  
Spring puller  
Small flat screwdriver

### REMOVAL OF STOCK EXHAUST SYSTEM:

1. Put the motorcycle on a side stand, we recommend a racing stand. Make sure, that surface is solid and flat.
2. Remove the bolt and plastic fasteners from the lower part of the cowling (**Figure 1, 2, 3**).



Figure 1



Figure 2



Figure 3

3. Untighten the metal clamps at the mufflers - link pipes joints (**Figure 4**). Unscrew the bolts from the muffler chassis hanging brackets (**Figure 5**). Remove the mufflers and the gaskets (**Figure 6, 7, 8**).



Figure 4



Figure 5



Figure 6



Figure 7



Figure 8

### **INSTALLATION OF THE AKRAPOVIC SLIP-ON EXHAUST SYSTEM:**

1. Install Akrapovic graphite sleeve gaskets into the link pipes. Coat the bolts and interior of metal clamps with Akrapovic anti-seize lead-free copper paste (black tube) and correctly install the metal clamps onto the link pipes (**Figure 9**). Slide the link pipes onto the stock collector and hand tighten the bolts of link-pipe clamps (**Figure 10**).



Figure 9



Figure 10

2. Correctly position the carbon-fiber clamps and slide them onto the mufflers - bear in mind **the left offset** of the carbon-fiber clamp viewed from the rear and **the right offset** for the left side. **!WARNING: open the clamps to slightly wider than the diameter of the outer sleeves of the mufflers – do not scrape it along the mufflers outer sleeves!** (**Figure 11**). Position the mufflers correctly and slide them onto the outlet side of the link pipes (**Figure 12**).



Figure 11



Figure 12

- Position and attach the springs; **WARNING!** make sure, that springs pull the mufflers all the way onto the link pipes – use rubber mallet if necessary to tap the connections into place! (Figure 13). Hand tighten the carbon-fiber clamps onto the stock brackets (Figure 14, 15). Tighten the metal clamps at the independent link pipe – stock collector connection (Figure 16).



Figure 13



Figure 14



Figure 15



Figure 16

- Tighten the bolts on the carbon-fiber clamp/stock muffler bracket joints (Figure 17). Make sure the link pipes or mufflers are not touching the frame and other parts. Attach the cowling in the reverse order from the order in which it was removed. (Figure 18, 19).



Figure 17



Figure 18

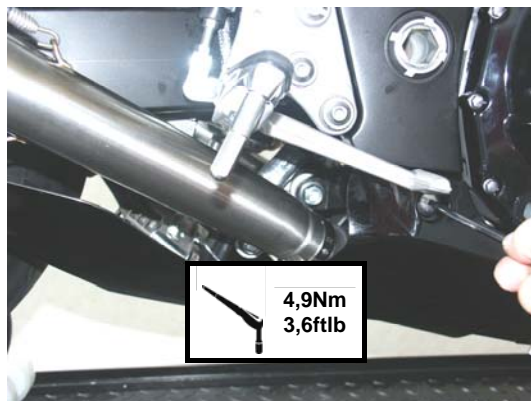

Figure 19

**Final installation:**

1. Clean grease spots:

- a. Muffler – carbon-fiber outer sleeves: use a soft dry cloth.
- b. Muffler – titanium outer sleeves: use a soft cloth sprayed with a multi-purpose spray lubricant (WD-40 or equivalent).
- c. Muffler – carbon-fiber outlet caps: use a soft dry cloth.
- d. Stainless steel link pipes: use a soft cloth sprayed with a contact cleaner, then wipe with a soft dry cloth.

Cleaning will prevent spots from burning onto the surface. Do not use aggressive chemical cleaners, because they can damage the sticker.

Position of the correctly installed Akrapovic **SLIP-ON** system (Figure 20).



Figure 20

2. Check the operation of the brakes and suspension. Make sure all the bolts are sufficiently tightened. In case the exhaust system touches the cowling or other parts repeat the adjustment of the exhaust system or contact your authorized dealer.

**! IT IS NORMAL IF WHITE SMOKE COMES OUT OF THE MUFFLER ON FIRST OPERATION.**

**! DO NOT STAND BEHIND THE MUFFLER ON FIRST OPERATION.**

**! DO NOT USE AUTOMOTIVE WHEEL CLEANERS OR ANY CLEANING PRODUCTS WHICH CONTAIN ACIDIC ADDITIVES TO CLEAN AKRAPOVIC EXHAUST SYSTEMS.**

#### **MAINTENANCE OF THE AKRAPOVIC EXHAUST SYSTEM**

1. Clean the titanium exhaust components with a multi-purpose spray lubricant (WD-40 or equivalent ), carbon fiber exhaust components with soft and dry cloth and stainless steel components with soft cloth sprayed with contact cleaner, then wipe with soft and dry cloth. Do not use aggressive chemical cleaners, because they can damage the sticker. A change in the color of the exhaust system is normal due to the high temperatures.
2. The wearing out of the muffler silencing material depends on the type of the engine and riding style. Contact your dealer/serviceman if visible changes appear on muffler's outer sleeve or the noise level is increased.
3. Periodically make sure all the bolts and springs are sufficiently tight.

# SUZUKI GSX-R1300 HAYABUSA, SLIP-ON exhaust system

Product code: S-S13SO2-RC  
S-S13SO2-RT

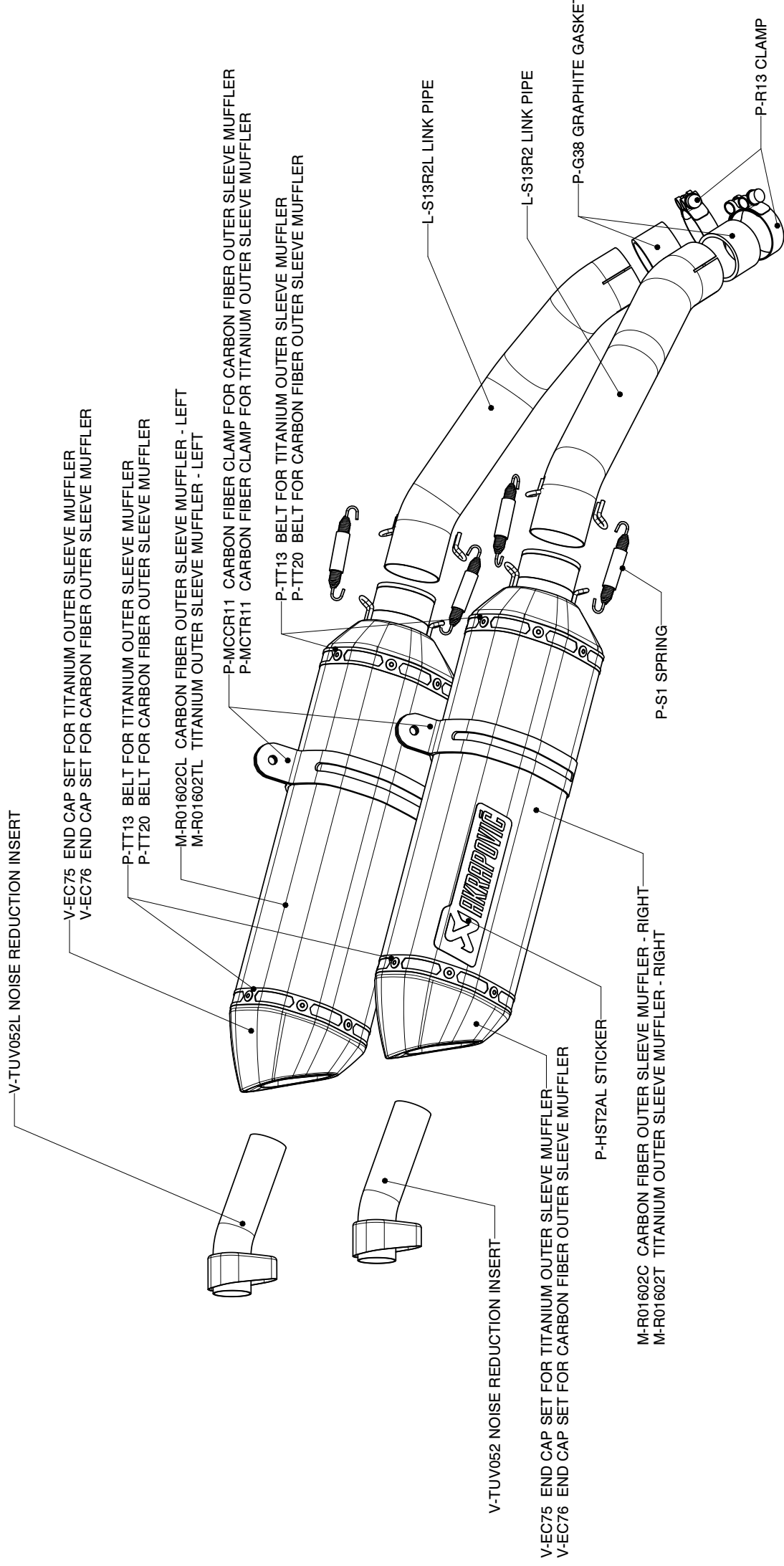

MUFFLER REPAIR KITS	
REPACK	P-RPCK31
SLEEVE	P-RKS217RT45 - TITANIUM
	P-RKS216RC45 - CARBON



# SUZUKI GSX-R1300 HAYABUSA, SLIP-ON exhaust system / Street legal

Product code: S-S13SO2-HRC  
S-S13SO2-HRT

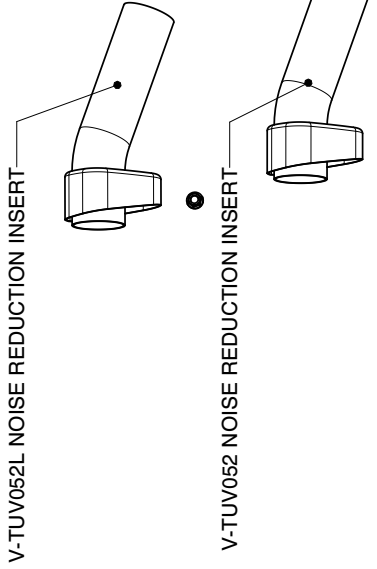
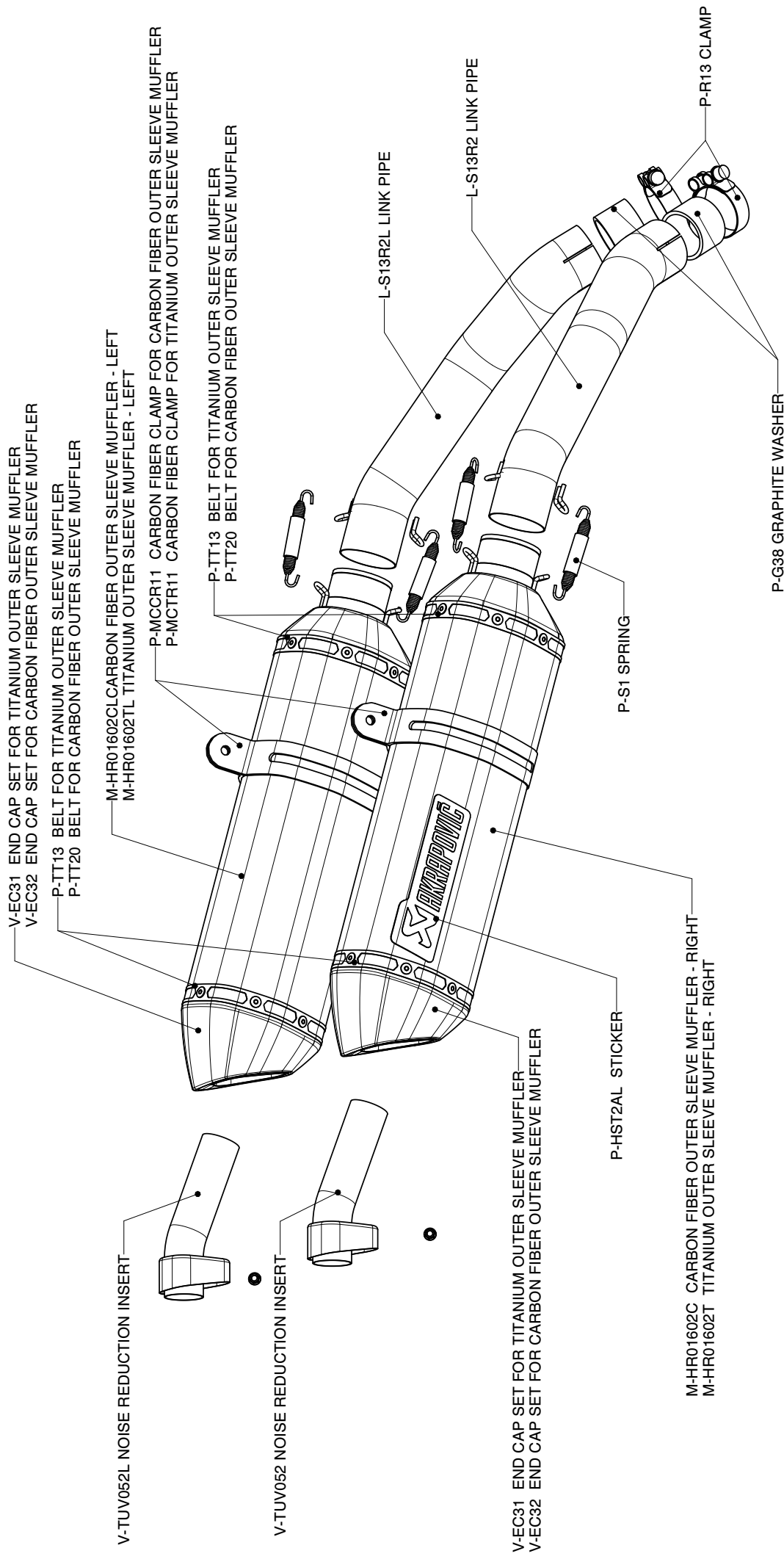

V-EC31 END CAP SET FOR TITANIUM OUTER SLEEVE MUFFLER  
V-EC32 END CAP SET FOR CARBON FIBER OUTER SLEEVE MUFFLER

MUFFLER REPAIR KITS	
REPACK	P-RPCK31
SLEEVE	P-RKS217RT45 - TITANIUM
	P-RKS216RC45 - CARBON

**SUZUKI GSX-R1300 Hayabusa, Complete exhaust system / Racing line tube set with street legal SLIP-ON mufflers - TWIN**  
**Product code: S-S13R2-HRC/1**  
**S-S13R2-HRT/1**

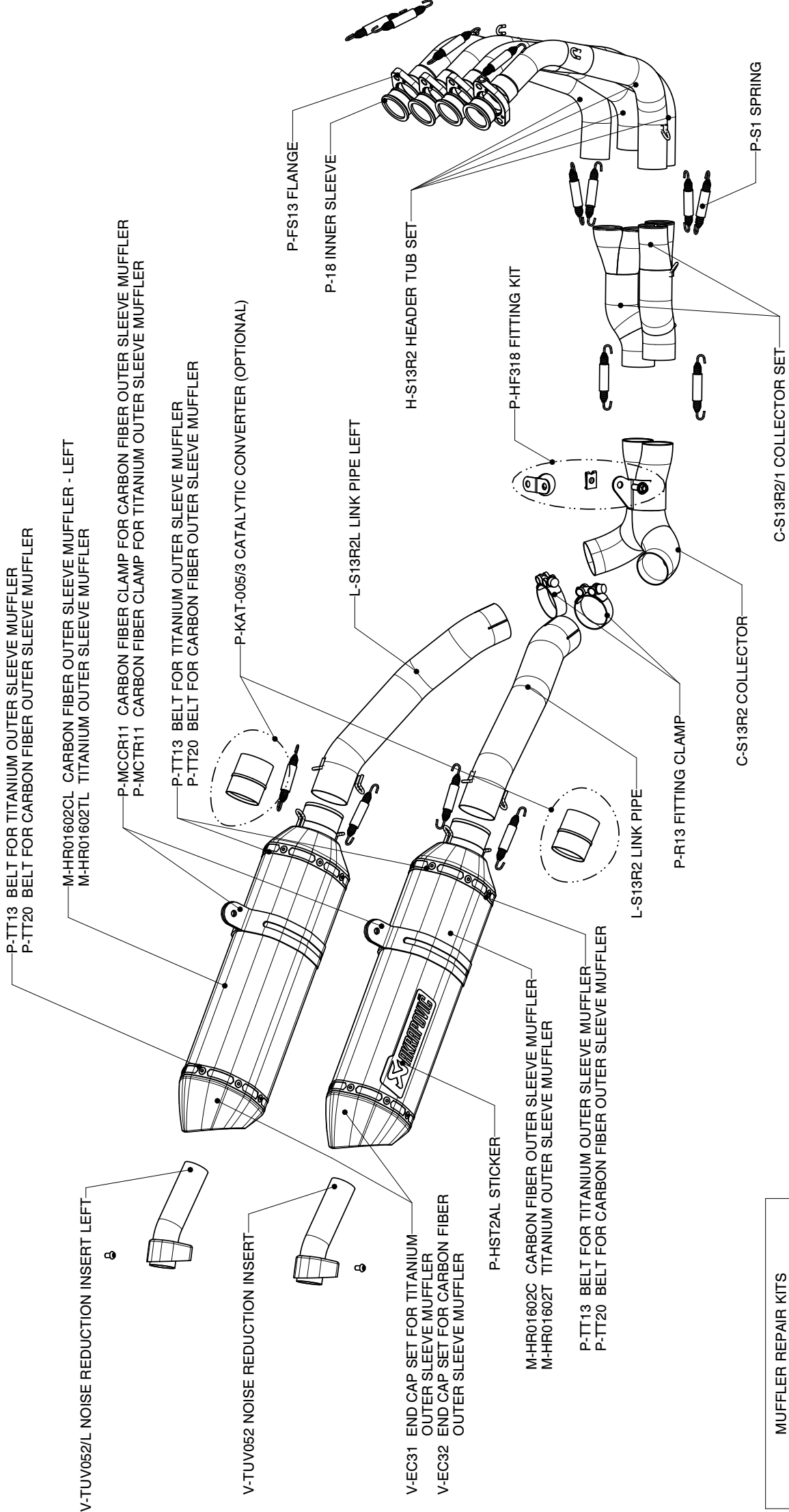

MUFFLER REPAIR KITS	
REPACK	P-RPCK31
SLEEVE	P-RKS217RT45 - TITANIUM P-RKS216RC45 - CARBON

**WARNING! IN CASE OF COMBINATION WITH RACING TUBE SET, THE SLIP-ON HOMOLOGATION IS NOT VALID!**

**WARNING:**

Please note that certain aftermarket exhaust systems may not comply with applicable California laws and regulations, and may therefore be prohibited for use on California highways or roads, or on roads or vehicles otherwise subject to emissions control requirements.

Akrapovič exhaust systems for automobiles and motorcycles mounted downstream of the catalytic converter (also known as “cat-back systems”) are considered “replacement parts” in California by the California Air Resources Board (CARB), and do not require an exemption or executive order from CARB to be sold in California. However, California prohibits the use of any aftermarket exhaust system that modifies, removes or replaces original equipment catalysts, unless CARB has issued an Executive Order as to such part or system.

Further, Akrapovič parts or exhaust systems used or intended for use on “racing vehicles” (i.e. a competition vehicle used exclusively for competition on closed-course circuits) do not require an exemption or Executive Order from CARB to be sold in California. However, such parts are prohibited from use on California public highways or roads, even if occasionally used “off-road.”